

SG 31

***STIHL***



2 - 13      Instruction Manual



## Contents

1	Guide to Using this Manual.....	2
2	Safety Precautions and Working Techniques.....	2
3	Assembling the Unit.....	6
4	Controls.....	6
5	Preparing Unit for Operation.....	8
6	Filling the Container.....	8
7	Spraying.....	8
8	After Spraying.....	9
9	Storing the Machine.....	9
10	Inspection and Maintenance by User.....	9
11	Maintenance and Care.....	11
12	Main Parts.....	11
13	Specifications.....	11
14	Troubleshooting.....	12
15	Maintenance and Repairs.....	12
16	Disposal.....	12
17	EC Declaration of Conformity.....	12
18	UKCA Declaration of Conformity.....	13

Dear Customer,

Thank you for choosing a quality engineered STIHL product.

It has been built using modern production techniques and comprehensive quality assurance. Every effort has been made to ensure your satisfaction and trouble-free use of the product.

Please contact your dealer or our sales company if you have any queries concerning this product.

Your



Dr. Nikolas Stihl

## 1 Guide to Using this Manual

### 1.1 Pictograms

All the pictograms attached to the machine are shown and explained in this manual.

## 1.2 Symbols in text

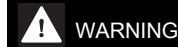

Warning where there is a risk of an accident or personal injury or serious damage to property.

### NOTICE

Caution where there is a risk of damaging the machine or its individual components.

## 1.3 Engineering improvements

STIHL's philosophy is to continually improve all of its products. For this reason we may modify the design, engineering and appearance of our products periodically.

Therefore, some changes, modifications and improvements may not be covered in this manual.

## 2 Safety Precautions and Working Techniques

This instruction manual covers a STIHL sprayer which is also referred to as the unit in the descriptions.



Special safety precautions must be observed when working with this sprayer.



It is important that you read the instruction manual before first use and keep it in a safe place for future reference. Non-observance of the instruction manual may result in serious or even fatal injury.

### 2.1 General

Observe all applicable local safety regulations, standards and ordinances.

If you have not used this model before: Have your dealer or other experienced user show you how it is operated or attend a special course in its operation.

Minors should never be allowed to use this product.

Keep bystanders, especially children, and animals away from the work area.

When the sprayer is not in use, put it in a place where it does not endanger others. Secure it against unauthorized use.

The user is responsible for avoiding injury to third parties or damage to their property.

Do not lend or rent your sprayer without the instruction manual. Be sure that anyone using it understands the information contained in this manual.

Do not operate your sprayer if any of its components are damaged. Make sure that all components are properly sealed – no leaks.

Pressurize the tank only with the pump that is installed in the sprayer.

Operate the sprayer only if it is complete and properly assembled.

To operate this sprayer you must be rested, in good physical condition and mental health.

Do not operate the sprayer if you are under the influence of any substance (drugs, alcohol) which might impair vision, dexterity or judgment.

## 2.2 Intended use

The sprayer is suitable for spraying chemicals and other liquids to control pests and weeds. Typical areas of application are in fruit and vegetable growing, horticulture, plantations, grassland and the forestry industry.

Only use plant protection products that are specifically approved for use in sprayers.

Do not use your sprayer for any other purpose because of the increased risk of accidents and damage to the sprayer. Never attempt to modify your sprayer in any way since this may result in accidents or damage to the sprayer.

## 2.3 Clothing and Equipment

Wear proper protective clothing and equipment when using, filling and cleaning the sprayer. Follow the chemical manufacturer's instructions with respect to protective equipment.

Clothing must be snug-fitting but allow complete freedom of movement.

Immediately change work clothes contaminated with plant control chemicals.



For some chemicals it is necessary to wear impermeable coveralls.

If you are spraying overhead, wear impermeable head covering.



Wear impermeable safety boots with a non-slip sole which are resistant to plant control chemicals.

Do not wear sandals or go barefoot.



Wear impermeable gloves resistant to plant control chemicals.



### WARNING



To reduce the risk of eye injuries, wear snug-fitting safety glasses in accordance with European Standard EN 166. Make sure the safety glasses are a good fit.

Wear a suitable respirator.

Inhaling plant control chemicals may endanger your health. Always wear a suitable respirator to protect yourself against health risks and allergic reactions. Observe warnings in the directions for use of the plant protection product and all applicable local safety regulations, standards and ordinances.

## 2.4 Transport

Transporting in a vehicle:

- Properly secure the sprayer to prevent turnover and damage.
- The tank must be de-pressurized, empty and clean.

## 2.5 Cleaning

Clean plastic surfaces with a cloth. Do not use aggressive detergents. They may damage the plastic.

Do not use a pressure washer to clean the unit. The solid jet of water may damage parts of the unit.

## 2.6 Accessories

Only use parts and accessories that are explicitly approved for this tool by STIHL or are technically identical. If you have any questions in this respect, consult a servicing dealer. Use only high quality parts and accessories in order to avoid the risk of accidents and damage to the tool.

STIHL recommends the use of genuine STIHL replacement parts. They are specifically designed to match your model and meet your performance requirements.

Never attempt to modify your tool in any way since this may increase the risk of personal injury. STIHL excludes all liability for personal injury and damage to property caused while using unauthorized attachments.

## 2.7 Handling Chemicals

Read the instructions supplied with the plant protection chemical prior to use. Follow the instructions with respect to mixing, using, personal protection equipment, storage and disposal.

Observe legal requirements for handling plant protection chemicals.

Plant protection chemicals may contain substances that are harmful to humans, animals, plants and the environment – **risk of poisoning and risk of serious or fatal injuries!**

Avoid contact with plant protection chemicals.

Plant protection chemicals may be used only by persons trained in their handling and the appropriate first-aid measures.

Keep instructions or label of the plant protection chemical available at all times in order to inform the doctor about the chemical concerned in an emergency. In an emergency, follow the chemical manufacturer's instructions provided or on the label. **Observe manufacturer's safety data sheets.**

### 2.7.1 Mixing plant protection chemicals and filling tank

Use plant protection chemicals only as specified by the manufacturer.

- Before filling the tank with chemicals, carry out a test with fresh water and check all parts of the sprayer for leaks.
- Never apply undiluted liquid concentrates of plant protection products.
- Mix the plant protection chemical and fill the tank outdoors only or in well-ventilated locations.
- Only mix sufficient solution for the job in hand so that nothing is left over.
- Do not mix different plant protection products unless such a mixture is approved by the manufacturer.
- Mix different chemicals only in accordance with the manufacturer's instructions – incorrect mixtures may produce toxic fumes or explosive solutions.
- Stand the sprayer on a level surface – do not fill the tank above the maximum mark.

- When filling from central water supply, do not immerse the end of the hose in the solution – sudden low pressure in the system may cause the solution to be sucked back into the water supply.
- **To reduce the risk of injury**, do not fill the sprayer while carrying it.
- Close the tank tightly after filling.

### 2.7.2 Application

- Work only in the open or in very well ventilated locations, e.g. open greenhouses.
- Do not eat, drink or smoke while working with plant control chemicals.
- Never blow through nozzles or other components by mouth.
- Do not spray in windy conditions.

Too high or too low a spray pressure or unfavorable weather conditions can result in the wrong solution concentration. Overdosing may damage plants and the environment. Under-dosing may result in unsuccessful plant treatment.

To reduce the risk of damage to plants and the environment, do not operate the sprayer:

- if pressure is too high or too low
- in windy conditions
- at temperatures above 30 °C in the shade
- in direct sunlight

In order to reduce the risk of accidents and damage to the sprayer, never operate the sprayer with:

- flammable liquids
- viscous or sticky liquids
- caustic or corrosive chemicals
- liquids hotter than 30 °C

### 2.7.3 Storage

- During work breaks, do not leave the sprayer in the hot sun or near any heat source.
- Do not store plant protection chemical in the sprayer for longer than one day.
- Store and transport plant protection products only in approved containers.
- Never store the plant protection products in containers intended for foods, drinks or animal feed.
- Do not store plant protection products with foods, drinks or animal feed.
- Keep plant protection products out of the reach of children and animals.
- Store the sprayer empty and clean. It must not be under pressure.
- Store plant protection products and power tool in a place secured against unauthorized use.

- Store the unit in a dry place protected from frost.

### 2.7.4 Disposal

Dispose of plant protection chemicals in accordance with environmental requirements – follow instructions of chemical manufacturer.

- Never dispose of residual plant protection products or contaminated rinsing solutions in waterways, drains, sewers, street gutters or manholes.
- Dispose of residual chemicals and used containers in accordance with local waste disposal regulations.

## 2.8 Holding and Guiding the Tool

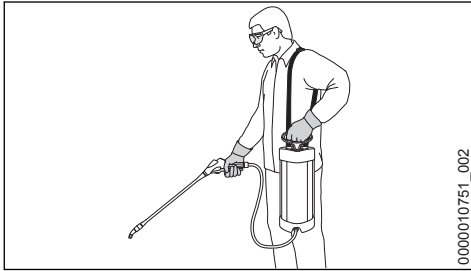

Put the strap over your left shoulder so that the unit hangs at your side. To ensure the unit can be quickly thrown off in an emergency, do not wear the strap across your chest.

Hold the sprayer with your right hand on the spray gun and your left hand on the pump handle.

Walk slowly forward as you work – observe the spray lance at all times – do not walk backward – **risk of stumbling.**

Keep the device upright to prevent spillage from the solution container and resulting **risk of injury!**

## 2.9 During Operation

Never spray in the direction of bystanders – **risk of injury.**

**Take special care in slippery conditions** – damp, snow, ice, on slopes or uneven ground.

Watch out for obstacles: Be careful of refuse, tree stumps, roots and ditches which could **cause you to trip or stumble.**

**To reduce the risk of accidents,** take a break in good time to avoid tiredness or exhaustion.

Work calmly and carefully – in daylight conditions and only when visibility is good. Stay alert so as not to endanger others.

Never work on a ladder or any other insecure support.

When working in open ground and gardens take special care to avoid harming small animals.

To reduce the **risk of electrocution,** never work in the vicinity of live wires or power cables.

Always clean the sprayer before changing to a different plant protection product.

## 2.10 After Finishing Work

Check all parts of the unit for leaks.

After finishing work, thoroughly clean the unit and wash your hands, face and, if necessary, your clothes.

Keep other persons and animals away from the areas that have been sprayed and do not walk on them until the plant protection chemical has dried.

## 2.11 Maintenance and Repairs

Do not attempt any maintenance or repair work not described in the instruction manual. Have all other work performed by a servicing dealer.

STIHL recommends that you have servicing and repair work carried out exclusively by an authorized STIHL servicing dealer. STIHL dealers are regularly given the opportunity to attend training courses and are supplied with the necessary technical information.

Only use high-quality replacement parts in order to avoid the risk of accidents and damage to the unit. If you have any questions in this respect, consult a servicing dealer.

STIHL recommends the use of genuine STIHL replacement parts. They are specifically designed to match your model and meet your performance requirements.

Always clean and empty the tank and release pressure in the sprayer before carrying out any maintenance or repair work.

When cleaning the tank, tube and hose system, make sure that other persons are not endangered by escaping liquid – **risk of injury.**

### 3 Assembling the Unit

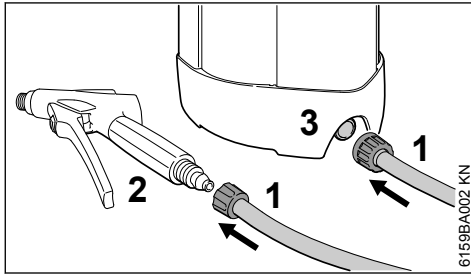

- ▶ Connect the hose (1) to the spray gun (2).
- ▶ Connect the hose (1) to the solution tank (3).

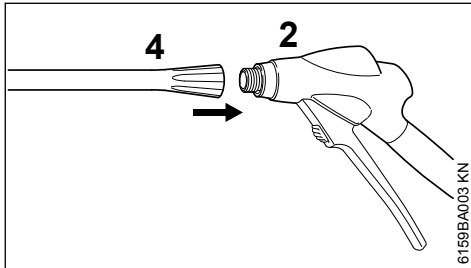

- ▶ Connect the wand (4) to the spray gun (2).

#### 3.1 Shoulder strap

- ▶ Pull the buckle off the shoulder strap.

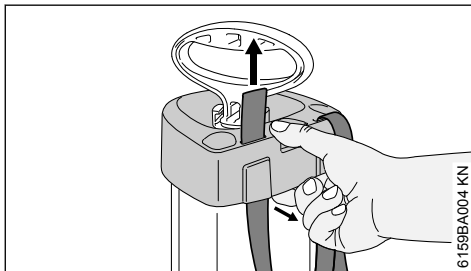

- ▶ Ease the housing outwards and thread the strap through the openings from below.

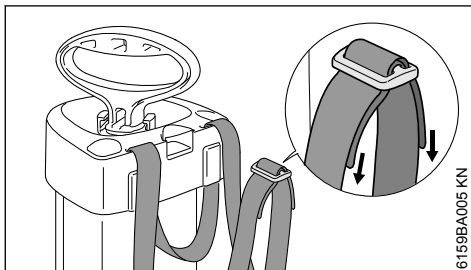

- ▶ Thread the ends of the strap through the buckle.

### 4 Controls

Make yourself familiar with how the components function before using your sprayer for the first time.

#### 4.1 Pump

##### Locking the pump handle

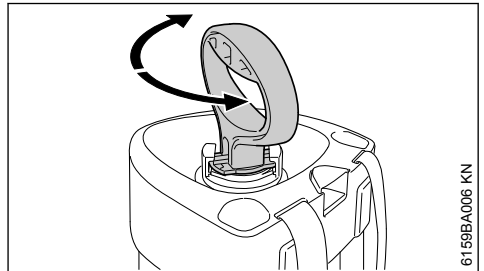

- ▶ Push the pump handle downward and turn it until it engages.

Lock the pump handle:

- While working
- When screwing the pump into the solution container – rotate clockwise
- To unscrew the pump from the solution container – rotate counterclockwise.

##### Unlocking the pump handle

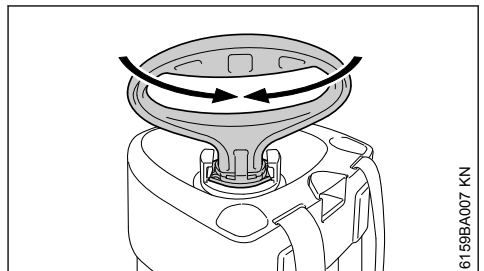

- ▶ Turn the pump handle by approx. one quarter turn until it is unlocked and can be freely moved up and down.

Unlock the pump handle:

- To pressurize the solution container.

## 4.2 Solution Container

### Pressurizing the solution container

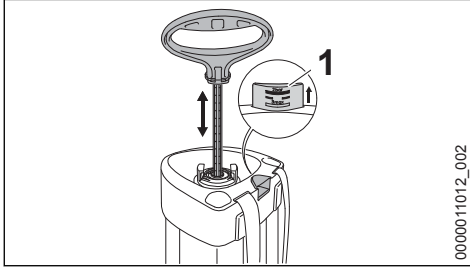

- ▶ Move the pump handle up and down several times – the pressure in the solution container rises

The scale on the piston manometer (1) shows the pressure in the solution container.

The higher the pressure in the solution container, the higher the piston manometer rises – maximum operating pressure is 3 bar (43.50 PSI).

If the maximum operating pressure is exceeded, the safety valve in the piston manometer releases the excess pressure.

### Releasing pressure in solution container

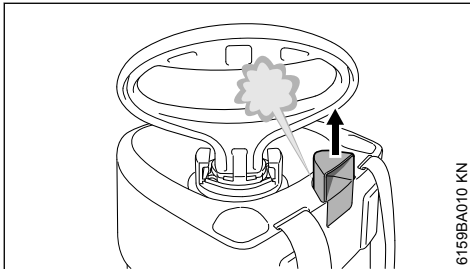

- ▶ Pull the piston manometer on the handle up all the way – pressure is released – wait until the solution container is completely depressurized.

Pressure must be released:

- Before filling the container
- After spraying
- To drain and clean the container
- Before carrying out any maintenance tasks

## 4.3 Spray gun

### Unlocking / locking spray gun

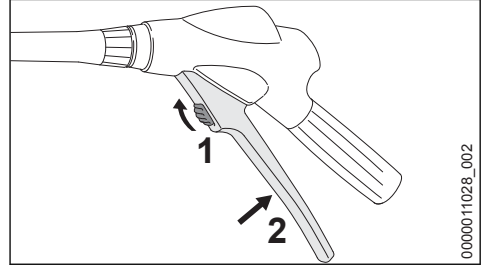

- ▶ Push locking lever (1) upward – the trigger (2) is unlocked and can be operated.

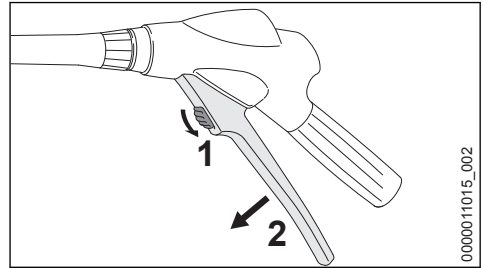

- ▶ Push the locking lever (1) downward – the trigger (2) is locked to reduce the risk of accidental operation.

## 4.4 Spray lance extension

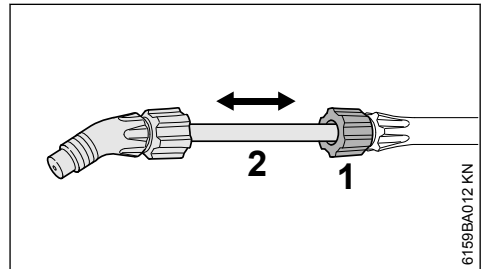

- ▶ Loosen the union nut (1).
- ▶ Pull the spray lance extension (2) out to the required length and line it up – nozzle orifice facing down.
- ▶ Tighten down the union nut (1) firmly.

## 4.5 Changing the Nozzle

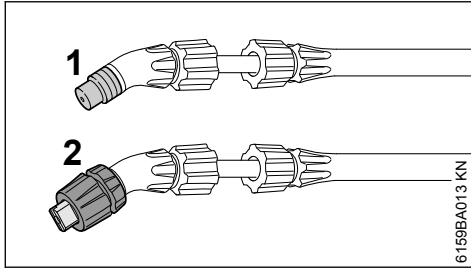

A hollow cone nozzle (1) or fan jet nozzle (2) can be fitted to suit requirements.

## 5 Preparing Unit for Operation

### 5.1 Visual Inspection

Do not operate your unit if any of its components are damaged. It is particularly important to check the tank and hose connection for leaks.

### 5.2 Checking for Leaks

Carry out test with the tank empty.

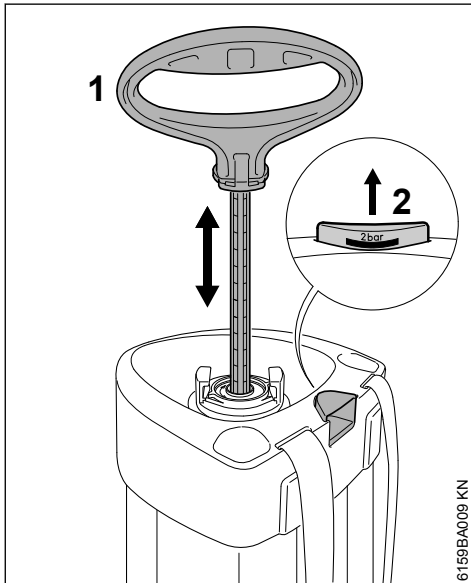

- ▶ Pressurize the tank – move the unlocked pump handle (1) up and down several times until piston manometer (2) shows a pressure of 2 bar (29 PSI).

The pressure in the tank must not drop any more than 0.5 bar (7.25 PSI) within the next 30 minutes.

- ▶ Operate spray gun trigger – pressure must escape.
- ▶ Release spray gun trigger – pressure must not escape.
- ▶ Pull out piston manometer – pressure must escape audibly.
- ▶ Completely depressurize the tank.

## 6 Filling the Container

The tank must not be under pressure.

- ▶ Unscrew the pump from the tank.
- ▶ Stand the container securely on a level surface.

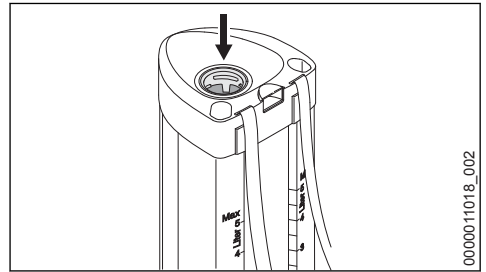

- ▶ Pour thoroughly mixed spray solution through the opening (arrow) – do not exceed maximum capacity (check max. mark on scale).
- ▶ Screw the pump back into the container.

## 7 Spraying

### 7.1 Visual inspection

Do not operate your machine if any of its components are damaged. It is particularly important to check the solution container and hose connections for leaks.

### 7.2 Spraying

- ▶ Build up pressure – move the pump handle up and down several times until the piston manometer shows the required rated pressure – see "Pressures / Spray Rates".
- ▶ Locking the pump handle.

Rated pressure / spray rates – see "Specifications".



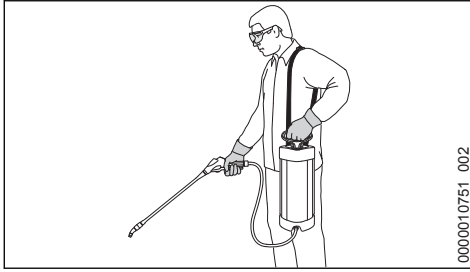

0000010751\_002

- ▶ Put the strap over your left shoulder so that the solution container hangs at your side.
- ▶ Operate the gun and always pay attention to the optimal rated pressure while spraying.
- ▶ If the rated pressure drops by more than 0.5 bar (7.25 PSI), restore it by operating the pump handle.

## 8 After Spraying

- ▶ Completely depressurize the tank.
- ▶ Unscrew the pump from the tank.
- ▶ Drain the tank in a well-ventilated location – collect remaining solution in a suitable container.

Dispose of any residual spray solution in accordance with environmental requirements – follow instructions of chemical manufacturer.

- ▶ Rinse the tank with clean water.
- ▶ Fill the tank with clean water, pump and spray until the tank is empty and completely depressurized.
- ▶ Wipe down the whole unit with a damp cloth.

## 9 Storing the Machine

- ▶ Keep tank and pump separate for drying and storage.
- ▶ Dry the unit and store it in a place protected from direct sunlight and frost.

## 10 Inspection and Maintenance by User

### 10.1 Pump

#### Removal

- ▶ Unscrew the pump from the solution container.
- ▶ Hold pump firmly by the cylinder barrel and unlock the pump handle.

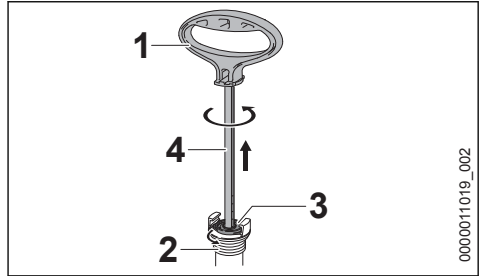

0000011019\_002

- ▶ Pull the pump handle (1) out of the cylinder barrel (2) as far as the limit stop.
- ▶ Pull the pump handle and rotate it counter-clockwise until the gland (3) is released from the cylinder barrel.
- ▶ Pull the piston rod (4) out of the cylinder barrel.

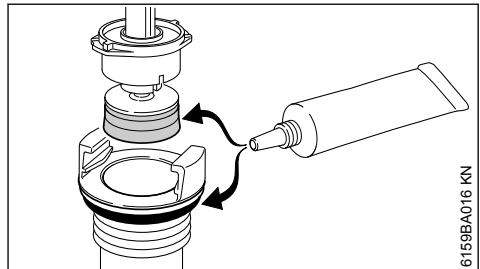

6159BA016 KN

- ▶ Lubricate the piston cup seal and O-ring with a food-safe grease.

#### Installation

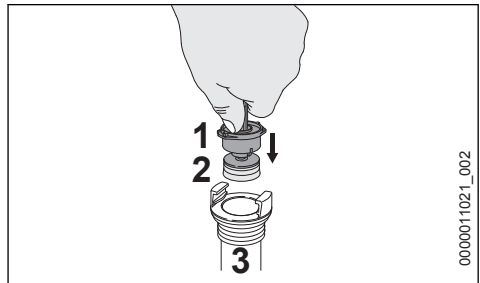

0000011021\_002

- ▶ Push the gland (1) with piston cup seal (2) into the cylinder barrel (3).
- ▶ Hold the gland (1) steady with your thumb and push it into the cylinder barrel.

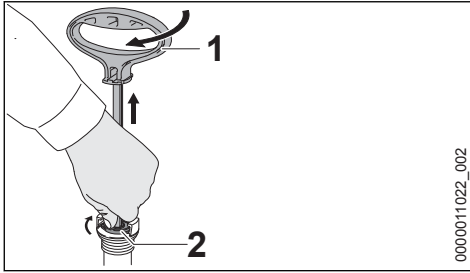

0000011022\_002

- ▶ Pull the pump handle (1) upward as far as the limit stop.
- ▶ Rotate the pump handle (1) clockwise – until the gland (2) engages the cylinder barrel.
- ▶ Push the pump handle (1) downward and lock it in position.
- ▶ Screw the pump into the solution container.

## 10.2 Cleaning the Filter

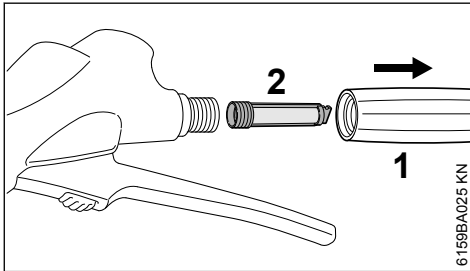

6159BA025 KN

- ▶ Unscrew the handle (1) from the spray gun and take out the filter (2).

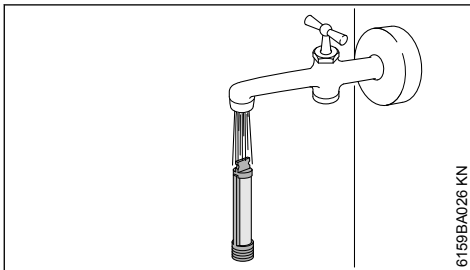

6159BA026 KN

- ▶ Rinse out the filter under running water.

## 10.3 Clean the nozzle

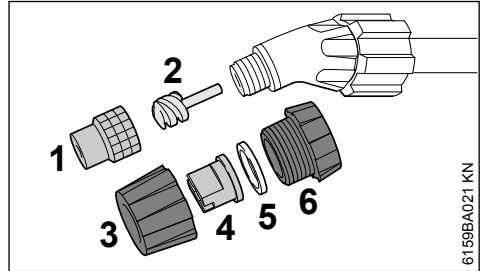

6159BA021 KN

- ▶ Unscrew the hollow cone nozzle (1) with spinner insert (2) from the spray lance

or

- ▶ Unscrew the fan-jet nozzle from the spray lance.
- ▶ Unscrew the union nut (3) from the body of the nozzle (6) and remove the nozzle (4) with the seal ring (5).

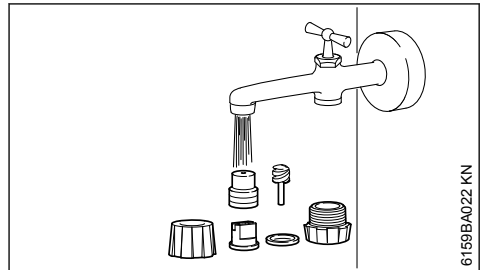

6159BA022 KN

- ▶ Rinse out all parts under running water and then reassemble

## 11 Maintenance and Care

The following intervals apply to normal operating conditions only. If your daily working times are longer, shorten the specified intervals accordingly.		before starting work	after finishing work or daily	weekly	monthly	every 12 months	if problem	if damaged	as required	after 50 refills
Complete unit	Visual inspection (condition, leaks)	X								
	Clean		X							
Tank, hose system, wand	Drain		X							
	Clean		X							
Nozzle	Clean		X				X			
Filter	Clean					X	X			X
Piston cup seal	Lubricate with grease					X	X			X
O-ring	Lubricate with grease					X				X
Safety labels	Replace							X		

## 12 Main Parts

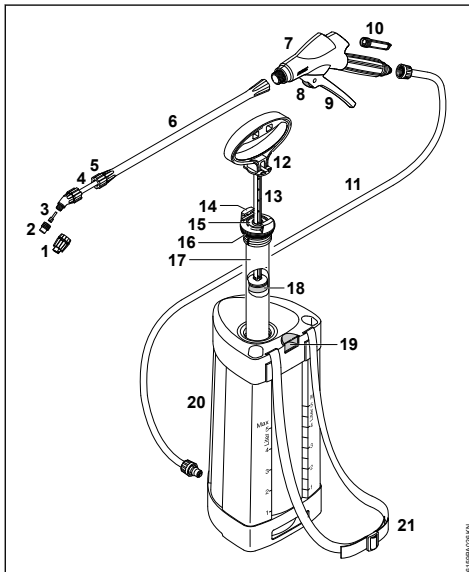

- 1 Fan jet nozzle
- 2 Hollow cone nozzle
- 3 Spinner insert

- 4 Wand extension
- 5 Union nut
- 6 Spray wand
- 7 Spray gun
- 8 Locking lever
- 9 Trigger
- 10 Filter
- 11 Hose
- 12 Pump handle
- 13 Piston rod
- 14 Latch on pump cylinder
- 15 Gland
- 16 O-ring
- 17 Pump cylinder
- 18 Piston cup seal
- 19 Piston manometer / relief valve
- 20 Tank
- 21 Shoulder strap

## 13 Specifications

### 13.1 Hydraulic Data

Spray pressure, max.:	3 bar (43.5 PSI)
Flow volume, max.:	1.0 l/min (61 cu.in/min)

Solution capacity, max.: 5 l (1.3 US gals)  
 Total capacity: 6.4 l (1.7 US gals)  
 Operating temperature, max.: 30°C (86°F)  
 Residual solution in tank: <0.04 l (1.4 fl.oz)  
 Recoil force: <5 N (1.1 lbf)

1.5 bar 0.49 l/min (30 cu.in/min)  
 (21.75 PSI)  
 2.0 bar (29.0 PSI) 0.56 l/min (34 cu.in/min)  
 3.0 bar (43.5 PSI) 0.69 l/min (42 cu.in/min)

## 13.2 Weight

Dry weight: 1.3 kg (2.9 lbs)

### 13.1.1 Working Pressures / Spray Rates

Spray pressure Flow rate with hollow cone nozzle

## 14 Troubleshooting

**Before starting any service work, operate the sprayer until it is no longer under pressure – if pressure is not released, chemical may escape unexpectedly when working on the sprayer. After servicing, carry out test run with clean water.**

Condition	Cause	Remedy
Pumping action produces no pressure	Pump not tightened down properly	Lock the pump handle and tighten down the pump
	O-ring on pump damaged	Install new O-ring
	Piston cup seal damaged	Install new piston cup seal
Jet only – spray not atomized	Spinner insert in nozzle missing	Fit spinner insert in the nozzle
Nozzle does not spray – pressure in tank OK	Nozzle / spinner insert and/or filter blocked	Clean nozzle / spinner insert and/or filter
Liquid entering the pump	Valve disk dirty or damaged	Clean or replace valve disk
Piston manometer indicates no tank pressure; relief valve operates too soon	Piston manometer faulty	Replace the sprayer.

## 15 Maintenance and Repairs

Users of this machine may only carry out the maintenance and service work described in this user manual. All other repairs must be carried out by a servicing dealer.

STIHL recommends that you have servicing and repair work carried out exclusively by an authorized STIHL servicing dealer. STIHL dealers are regularly given the opportunity to attend training courses and are supplied with the necessary technical information.

When repairing the machine, only use replacement parts which have been approved by STIHL for this power tool or are technically identical. Only use high-quality replacement parts in order to avoid the risk of accidents and damage to the machine.

STIHL recommends the use of original STIHL replacement parts.

Original STIHL parts can be identified by the STIHL part number, the **STIHL** logo and the STIHL parts symbol  (the symbol may appear alone on small parts).

## 16 Disposal

Contact the local authorities or your STIHL servicing dealer for information on disposal.

Improper disposal can be harmful to health and pollute the environment.

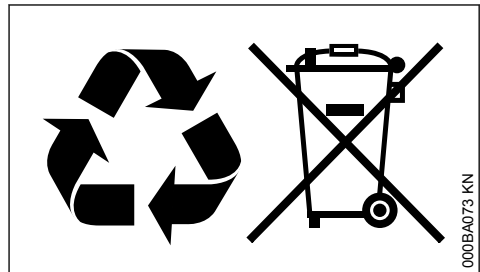

- ▶ Take STIHL products including packaging to a suitable collection point for recycling in accordance with local regulations.
- ▶ Do not dispose with domestic waste.

## 17 EC Declaration of Conformity

ANDREAS STIHL AG & Co. KG  
 Badstr. 115  
 D-71336 Waiblingen

Germany

declare in exclusive responsibility that the product

Category: Sprayer  
Make: STIHL  
Model: SG 31  
Serial identification: 4255

conforms to the specifications of Directive 2006/42/EC.

Technical documents deposited at:

ANDREAS STIHL AG & Co. KG  
Produktzulassung (Product Licensing)

Waiblingen, 15.07.2021

ANDREAS STIHL AG & Co. KG



Dr. Jürgen Hoffmann

Director Product Certification & Regulatory Affairs



Dr. Jürgen Hoffmann

Director Product Certification & Regulatory Affairs



## 18 UKCA Declaration of Conformity

ANDREAS STIHL AG & Co. KG  
Badstr. 115  
D-71336 Waiblingen

Germany

declare under our sole responsibility that

Category: Sprayer  
Manufacturer's brand: STIHL  
Series: SG 31  
Serial identification number: 4255

complies with the relevant provisions of the UK regulations Supply of Machinery (Safety) Regulations 2008.

Technical documents deposited at:

ANDREAS STIHL AG & Co. KG

Done at Waiblingen, 15.07.2021

ANDREAS STIHL AG & Co. KG

pp





[www.stihl.com](http://www.stihl.com)



0458-595-0121-C



0458-595-0121-C